

*HandyCore Usage*  
**HCS-03 Design Guidelines**  
*Application Note*

**2008. 10. 31**  
AN-2010-20E  
Version 1.1



## Copyright

All detailed information including pin-outs, electrical specifications, and design guidelines may be changed without notice.

HandyWave Co., Ltd.

202-4 Yatap-dong, Bundang-gu, Seongnam-shi, Gyunggi Province, 463-070, Republic of Korea

Tel: 82-31-709-8900, Fax: 82-31-708-9455, <http://www.handywave.com/index3.htm>

HCS-03 Design Guidelines, Application Note, AN-2010-20E, Version 1.1, 2008. 10. 31

Copyright© 2003 - 2008 HandyWave Co., Ltd. All right reserved.

## Contents

<b>1. INTRODUCTION.....</b>	<b>1-1</b>
1.1. KEY FEATURES .....	1-1
1.2. KEY SPECIFICATIONS.....	1-1
1.3. PACKAGES .....	1-1
1.4. RECORD OF CHANGES .....	1-2
1.5. ACRONYMS AND DEFINITIONS .....	1-2
1.6. REFERENCES.....	1-2
<b>2. SPECIFICATIONS .....</b>	<b>2-1</b>
2.1. HARDWARE OVERVIEW.....	2-1
2.2. HCS-03 PIN-OUT AND OUTLINE .....	2-2
2.3. TERMINAL FUNCTIONS .....	2-3
2.4. HCS-03 DIMENSIONS.....	2-5
2.5. HCS-03 LAND PATTERN RECOMMENDATION.....	2-6
2.6. HCS-03 CHARACTERISTICS.....	2-7
2.6.1. <i>Electrical Characteristics</i> .....	2-7
2.6.2. <i>Power Consumption</i> .....	2-7
2.6.3. <i>RF Characteristics</i> .....	2-8
2.6.3.1. Transmitter.....	2-8
2.6.3.2. Transceiver .....	2-8
2.6.3.3. Receiver .....	2-9
<b>3. DESIGN AND PRODUCTION GUIDELINES .....</b>	<b>3-1</b>
3.1. INTERNAL CHIP ANTENNA DESIGN .....	3-1
3.1.1. <i>Background information</i> .....	3-1
3.1.2. <i>PCB Design Options</i> .....	3-2
3.1.2.1. W5I-BF-LS Type .....	3-2
3.1.2.2. W5I-BF-RS Type .....	3-2
3.1.2.3. W5I-BF-LD Type.....	3-3
3.1.2.4. W5I-BF-RD Type .....	3-3
3.1.3. <i>Design Example and Analysis</i> .....	3-4
3.2. SMA CONNECTOR LAYOUT .....	3-5
3.2.1. <i>Shield CAN Information</i> .....	3-6
3.2.2. <i>Shield CAN Layout Information</i> .....	3-7

3.3. COMMON ERRORS IN HCS-03 PCB DESIGN ..... 3-8

    3.3.1. *Ground Land Design for HCS-03 (the center of HCS-03)*..... 3-8

    3.3.2. *Metal Conductors around Antenna*..... 3-8

    3.3.3. *Transmission Line (Antenna Signal Line) Design* ..... 3-8

    3.3.4. *Bottom Layer Design*..... 3-8

    3.3.5. *System Ground Design* ..... 3-8

    3.3.6. *Antenna Layout Design*..... 3-8

3.4. SMT PROCESS ..... 3-9

    3.4.1. *Metal Mask Recommendation*..... 3-9

    3.4.2. *Reflow Profile* ..... 3-10

3.5. REWORK GUIDELINES ..... 3-11

    3.5.1. *No Hot Gun at Rework* ..... 3-11

    3.5.2. *Rework* ..... 3-11

3.6. PACKAGE INFORMATION ..... 3-12

3.7. ORDERING INFORMATION ..... 3-12

3.8. CONTACT INFORMATION ..... 3-12

**ATTACHMENT 1. REFERENCE SCHEMATIC..... 1**

**ATTACHMENT 2. BILL OF MATERIALS..... 2**

## Table

TABLE 1-1 RECORD OF CHANGES .....	1-2
TABLE 1-2 ACRONYMS AND DEFINITIONS .....	1-2
TABLE 2-1 RADIO FUNCTIONS.....	2-3
TABLE 2-2 POWER SUPPLIERS FUNCTIONS .....	2-3
TABLE 2-3 UART INTERFACES.....	2-3
TABLE 2-4 SPI INTERFACES .....	2-3
TABLE 2-5 PIO INTERFACES .....	2-4
TABLE 2-6 OTHERS .....	2-4
TABLE 2-7 ELECTRICAL CHARACTERISTICS.....	2-7
TABLE 2-8 POWER CONSUMPTION .....	2-7
TABLE 2-9 TRANSMITTER PERFORMANCE.....	2-8
TABLE 2-10 TRANSCEIVER PERFORMANCE.....	2-8
TABLE 2-11 RECEIVER PERFORMANCE.....	2-9
TABLE 3-1 ORDERING INFORMATION .....	3-12

## Figure

FIGURE 2-1 HCS-03 HARDWARE CONFIGURATION .....	2-1
FIGURE 2-2 HCS-03 PIN-OUT .....	2-2
FIGURE 2-3 HCS-03 OUTLINE.....	2-2
FIGURE 2-4 HCS-03 DIMENSIONS.....	2-5
FIGURE 2-5 HCS-03 LAND PATTERN .....	2-6
FIGURE 3-1 A DESIGN EXAMPLE .....	3-1
FIGURE 3-2 W5I-BF-LS TYPE.....	3-2
FIGURE 3-3 W5I-BF-RS TYPE .....	3-2
FIGURE 3-4 W5I-BF-LD TYPE.....	3-3
FIGURE 3-5 W5I-BF-RD TYPE.....	3-3
FIGURE 3-6 EXAMPLE OF ARTWORK LAYOUT WITH W5I-BF-RD28 .....	3-4
FIGURE 3-7 SMA CONNECTOR ARTWORK LAYOUT .....	3-5
FIGURE 3-8 15.0 x 27.7 x 2.5 (MM) L TYPE SHIELD CAN .....	3-6
FIGURE 3-9 17.8 x 17.8 x 2.5 (MM) S TYPE SHIELD CAN .....	3-6
FIGURE 3-10 S TYPE SHIELD CAN LAYOUT.....	3-7
FIGURE 3-11 PARAMETERS OF COPLANAR WAVEGUIDE WITH GROUND .....	3-8
FIGURE 3-12 HCS-03 METAL MASK .....	3-9
FIGURE 3-13 HCS-03 REFLOW PROFILE .....	3-10
FIGURE 3-14 NO HOT GUN .....	3-11
FIGURE 3-15 QFP NOZZLE EXAMPLES .....	3-11
FIGURE 3-16 REWORK EXAMPLE.....	3-11

# 1. Introduction

---

This document is the design guidelines of HCS-03.

## 1.1. Key Features

- Supports Bluetooth Serial Port Profile and Generic Access Profile
- No need of external host and software
- Supports configuration of the local device and the remote device via Over-the-Air
- Supports up to 100 meter (Line of Sight)
- Supports Point-to-Point and Point-to-Multipoint Topology
- Supports the firmware upgrade locally
- Support an internal chip antenna or an external antenna with SMA connector
- RoHS Compliance

## 1.2. Key Specifications

- Standard: Bluetooth Specification Version 1.2 and/or above
- Operation Frequency: 2.4GHz ISM Band
- Transmitted Power: Max 18 / Typical 16dBm (Class 1)
- Received Sensitivity: better than -85dBm
- Power Supply: DC 3.3V
- Operation Temperature: -20 ~ 70 °C
- Baud Rate: 1.2, 2.4, 4.8, 9.6, 19.2, 38.4, 57.6, 115.2Kbps and up to 3Mbps
- UART Signal Level: TTL 3.3V
- Dimension: 13mm x 13mm x 1.6mm (LGA 36Pin)

## 1.3. Packages

- HCS-03 with Serial Firmware
- Internal Chip Antenna or External Dipole Antenna
- HCS-03 Shield CAN L type (15.0 x 27.7 x 2.5 (mm)) or S type (17.8 x 17.8 x 2.5 (mm))
- Supports FCC, CE, and local certifications

## 1.4. Record of changes

**Table 1-1 Record of changes**

Version	Date	Reason for changes
1.0	2008. 07. 14	Original publication of this information (HandyWave reference AN-2010-20E)
1.1	2008. 10. 31	Removed Figure 3-7 Added Shield CAN Information and Shield CAN Layout Information Updated Table 3-1 Ordering Information

## 1.5. Acronyms and Definitions

**Table 1-2 Acronyms and Definitions**

Acronym	Definition
ANT	Antenna
BlueCore	A series of Bluetooth chip from CSR
CSR	Cambridge Silicon Radio
DFU	Device Firmware Upgrade
HandyPort	A brand name of wireless serial adapter from HandyWave
HCS	HandyCore Serial
I2C	I-square-C
LNA	Low Noise Amplifier
MOQ	Minimum Order Quantity
PA	Power Amplifier
PCM	Pulse Code Modulation
PIO	Programmable Input Output
SPI	Serial Peripheral Interface
TBD	To Be Determined
UART	Universal Asynchronous Receiver Transmitter
USB	Universal Serial Bus

## 1.6. References

1. BlueCore4Databook, BC417143B-db-001Pg, Rev g, 2005. 07. 27, CSR

## 2. Specifications

This chapter describes the specifications of HCS-03.

### 2.1. Hardware Overview

The HCS-03 is based on the BC04-External from CSR. And it consists of a power port, an antenna port, interfaces, a crystal and a flash memory. The HCS-03 uses a UART, PIOs, and a SPI interfaces and it does not use a USB, a PCM, and an I2C interfaces.

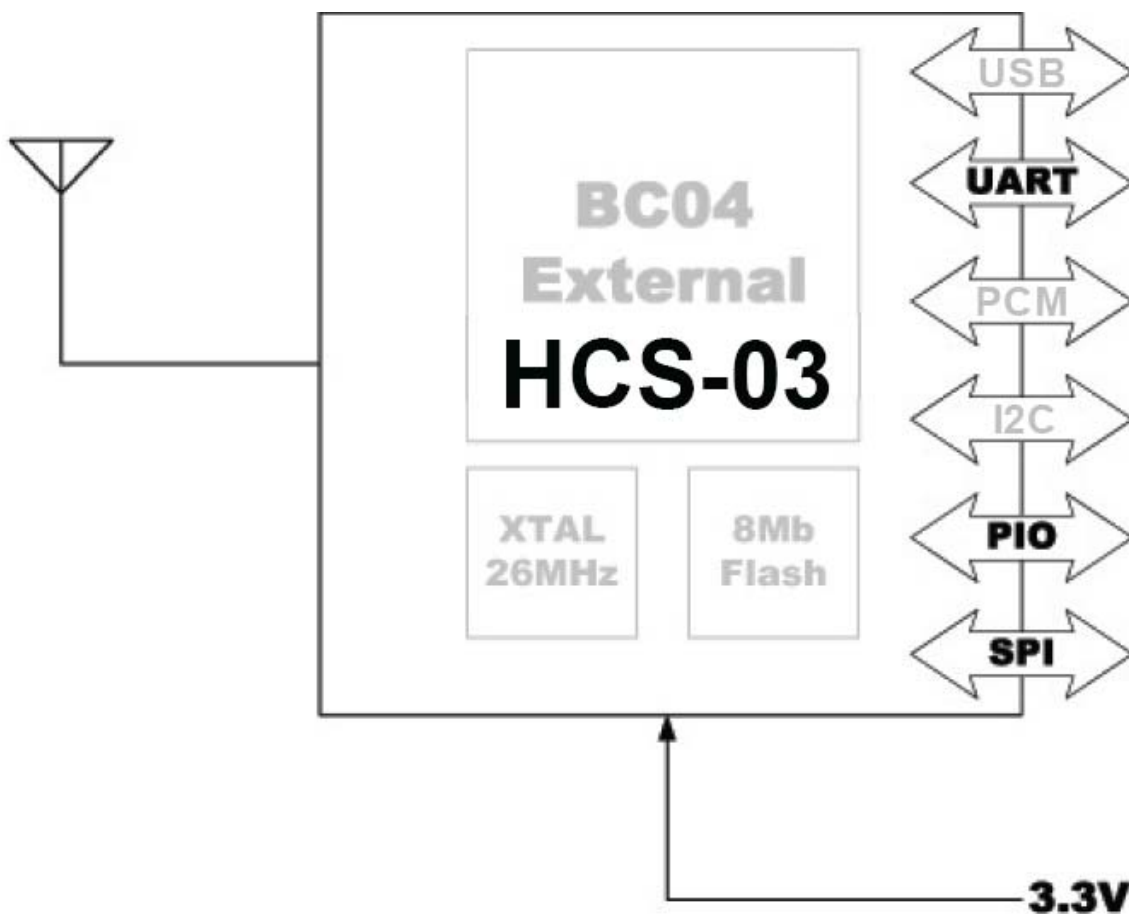

Figure 2-1 HCS-03 Hardware Configuration

## 2.2. HCS-03 Pin-out and Outline

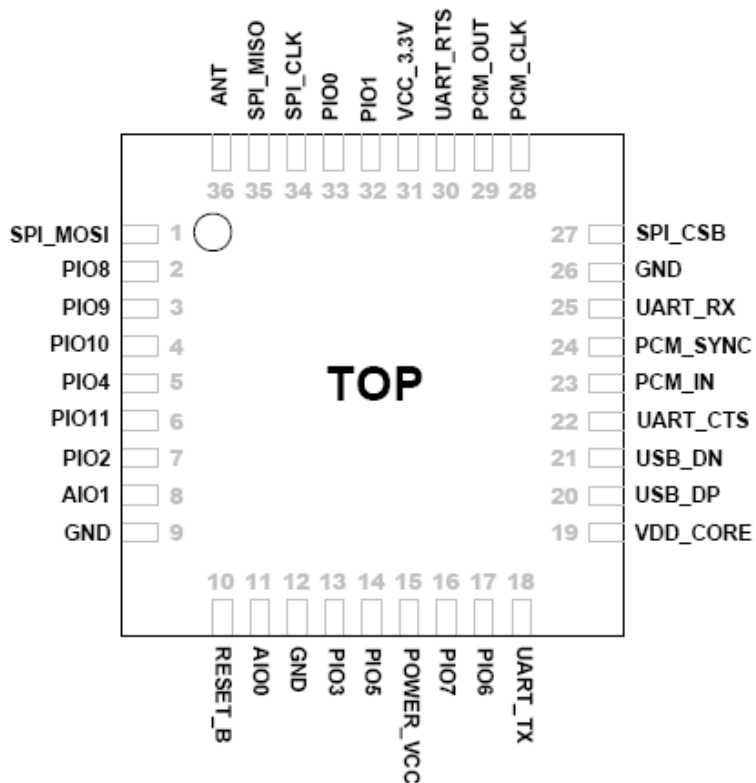

Figure 2-2 HCS-03 Pin-out

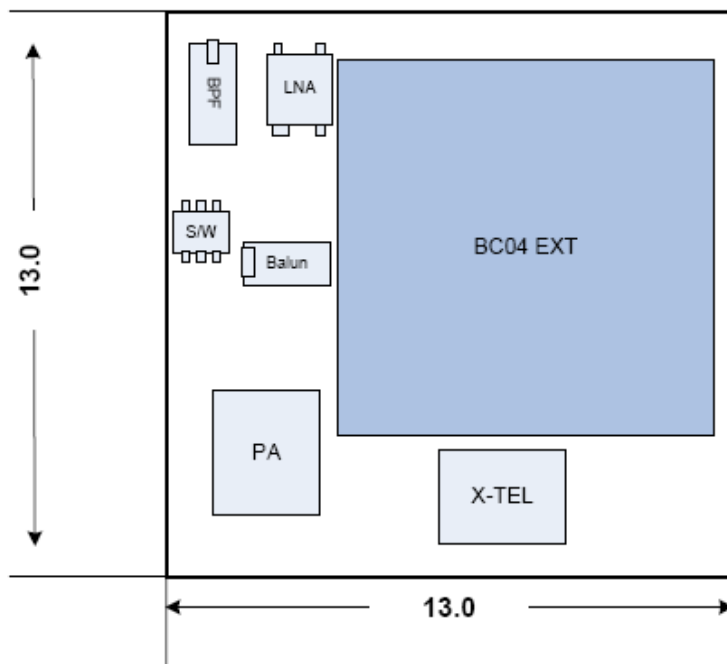

Figure 2-3 HCS-03 Outline

## 2.3. Terminal Functions

**Table 2-1 Radio Functions**

Function	Pin Name	Pin No.	Direction	Description
Radio	ANT	36	O	RF connection to antenna
	PIO0	33	O	Control output for external LNA
	PIO1	32	O	Control output for external PA

**Table 2-2 Power Suppliers Functions**

Function	Pin Name	Pin No.	Direction	Description
Power Suppliers	VCC_3.3V	31	I	DC input voltage for operation
	POWER_VCC	15	I	DC input voltage for operation
	VDD_CORE	19	O	Positive supply for internal digital circuit
	GND	9, 12, 26	N/A	Ground
	RESETB	10	I	Reset if low. Input debounced so must be low for >5ms to cause a reset

**Table 2-3 UART Interfaces**

Function	Pin Name	Pin No.	Direction	Description
UART Interface	UART_TXD	18	O	UART data output
	UART_RXD	25	I	UART data input
	UART_RTS	30	O	UART Request To Send, active low
	UART_CTS	22	I	UART Clear To Send, active low

**Table 2-4 SPI Interfaces**

Function	Pin Name	Pin No.	Direction	Description
SPI Interface	SPI_CSB	27	I	Chip select for Synchronous Serial Interface, active low
	SPI_CLK	34	I	SPI clock
	SPI_MISO	35	O	SPI data output
	SPI_MOSI	1	I	SPI data input

**Table 2-5 PIO Interfaces**

Function	Pin Name	Pin No.	Direction	Description
PIO Interface	PIO2	7	I/O	Programmable input/output line
	PIO3	13	I/O	Programmable input/output line
	PIO4	5	I/O	Programmable input/output line
	PIO5	14	I/O	Programmable input/output line
	PIO6	17	I/O	Programmable input/output line
	PIO7	16	I/O	Programmable input/output line
	PIO8	2	I/O	Programmable input/output line
	PIO9	3	I/O	Programmable input/output line
	PIO10	4	I/O	Programmable input/output line
	PIO11	6	I/O	Programmable input/output line

**Table 2-6 Others**

Function	Pin Name	Pin No.	Direction	Description
PCM Interface	PCM_OUT	29	O	Synchronous data output
	PCM_IN	23	I	Synchronous data input
	PCM_CLK	28	I/O	Synchronous data clock
	PCM_SYNC	24	I/O	Synchronous data sync
USB Interface	USB_DN	21	I/O	USB data minus
	USB_DP	20	I/O	USB plus
Others	AIO0	11	I/O	General purpose analogue interface
	AIO1	8	I/O	General purpose analogue interface

## 2.4. HCS-03 Dimensions

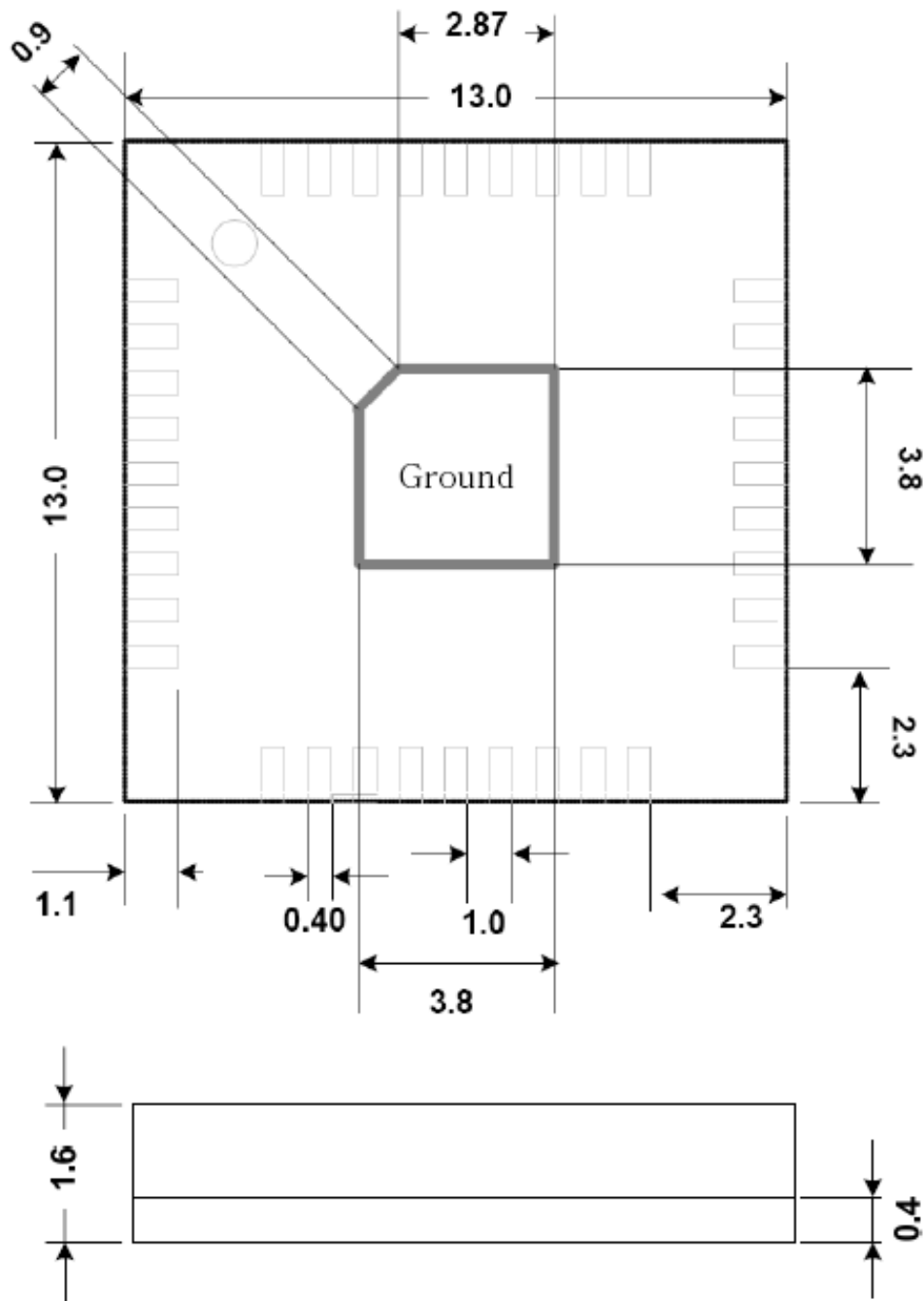

Figure 2-4 HCS-03 Dimensions

## 2.5. HCS-03 Land Pattern Recommendation

**The ground land in center of HCS-03 shall be connected to the system ground firmly and thoroughly.** If it is separated from the system ground or connected but only via a couple of patterns, it will be fatal for the RF performance.

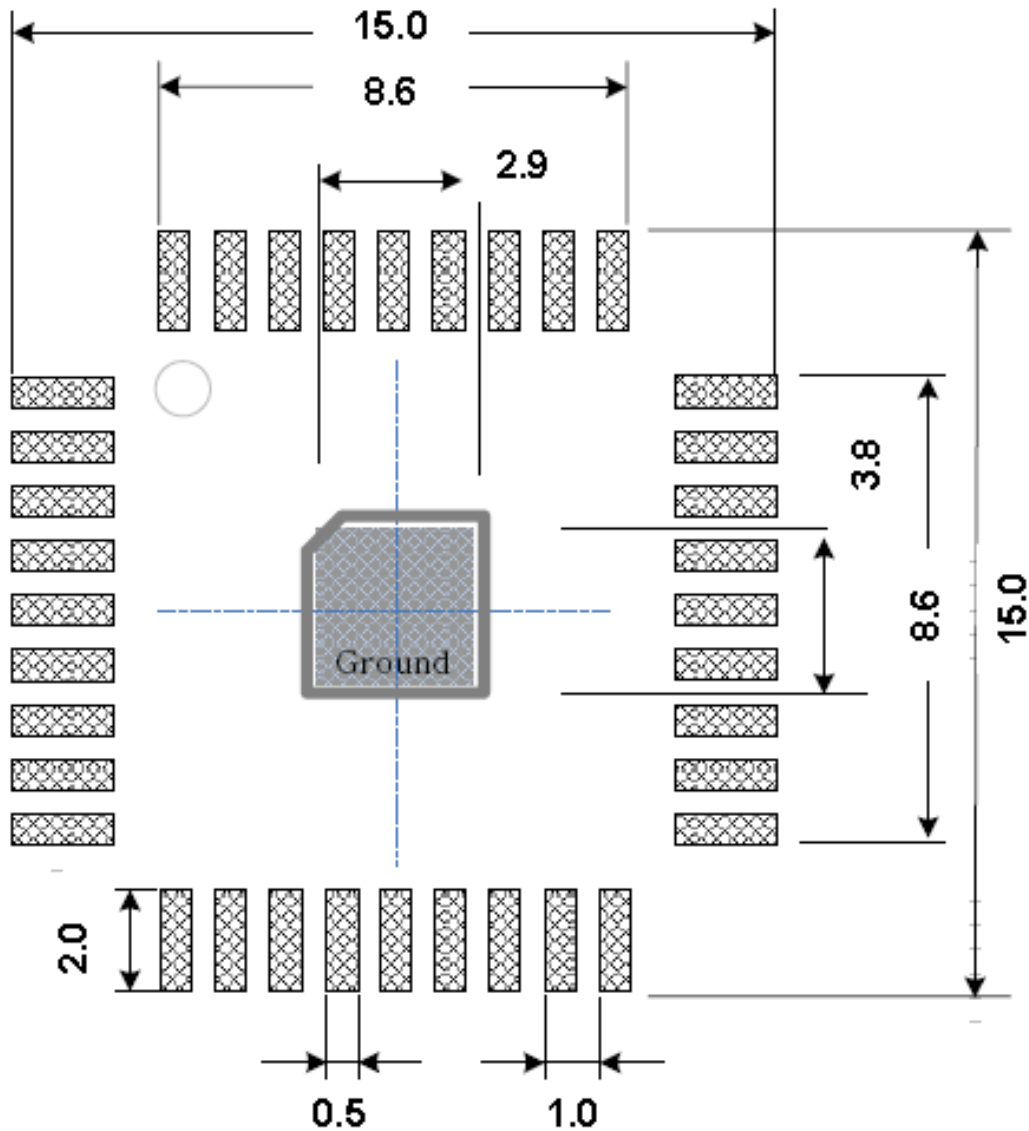

Figure 2-5 HCS-03 Land Pattern

## 2.6. HCS-03 Characteristics

This section describes the characteristics of HCS-03.

### 2.6.1. Electrical Characteristics

**Table 2-7 Electrical Characteristics**

<b>Absolute Maximum Ratings</b>		
Rating	Min	Max
Storage Temperature	-40 °C	+85 °C
Operating Temperature Range	-20 °C	+70 °C
Supply Voltage: VCC	+3.0V	+3.7V
Other Terminal Voltage	VCC – 0.4V	VCC + 0.4V
<b>Recommended Operating Conditions</b>		
Operating Condition	Min	Max
Operating Temperature Range	-20 °C	+70 °C
Supply Voltage: VCC	+3.0V	+3.3V
Supply Voltage: POWER_VCC	+3.0V	+3.3V

### 2.6.2. Power Consumption

**Table 2-8 Power Consumption**

Operation Mode	Role	UART Rate	Average	Unit
Inquiring	-	N/A	46	mA

## 2.6.3. RF Characteristics

## 2.6.3.1. Transmitter

Table 2-9 Transmitter Performance

Transmitter Performance					
Parameter	Condition	Min	Typ	Max	Unit
Output Power	Normal	-	16	18	dBm
Power Density	Normal	14	15	18	dBm
Power Control	Normal8	2	4	8	dBm
Frequency Range	Normal	2400	-	2483.5	MHz
20dB Bandwidth	Normal	-	926	930	KHz
Adjacent Characteristics	$\pm 2\text{Mz}$	-	-35	-20	dBm
	$\pm 3\text{Mz}$	-	-45	-40	dBm
	$\pm 4\text{Mz}$	-	-50	-40	dBm
Modulation Characteristics	$\Delta F1_{\text{avg}}$	160	165	170	KHz
	$\Delta F2_{\text{max}}$	153	160		KHz
	$\Delta F2_{\text{avg}} / \Delta F1_{\text{max}}$	98	100	-	%
Initial Carrier Frequency Tolerance	Normal	-20	2	20	KHz
Carrier Frequency Drift	One slot packet (DH1)	-15		20	KHz
	Three slot packet (DH3)	-15		20	KHz
	Five slot packet (DH5)	-15		20	KHz

## 2.6.3.2. Transceiver

Table 2-10 Transceiver Performance

Transceiver Performance					
Parameter	Condition	Min	Typ	Max	Unit
Out-of-Band Spurious Emissions	30MHz ~ 1MHz	-	-	-36	dBm
	1GHz ~ 12.75GHz	-	-	-40	dBm
	1.8GHz ~ 5.3GHz	-	-	-47	dBm
	5.1GHz ~ 5.3GHz	-	-	-47	dBm

2.6.3.3. Receiver

Table 2-11 Receiver Performance

Receiver Performance					
Parameter	Condition	Min	Typ	Max	Unit
Sensitivity Level	Single slot packets	-85	-87	-	dBm
	Multi slot packets	-85	-87	-	dBm
C/I Performance	C/I <sub>co-channel</sub>	-	-	11	dB
	C/I <sub>1MHz</sub> (Adjacent channel selectivity)	-	-	0	dB
	C/I <sub>2MHz</sub> (Adjacent channel selectivity)	-	-	-30	dB
	C/I <sub>≥3MHz</sub> (Adjacent channel selectivity)	-	-	-40	dB
Blocking Performance	30MHz ~ 2000MHz	-10			dBm
	2000MHz ~ 2400MHz	-27			dBm
	2500MHz ~ 3000MHz	-27			dBm
	3000MHz ~ 12.75MHz	-10			dBm
Intermodulation Performance	N=5	-39	-		dBm
Maximum Input Level		-20	-17		dBm

No text.

## 3. Design and Production Guidelines

This chapter describes the design and the production guidelines.

### 3.1. Internal Chip Antenna Design

We provide internal chip antennas such as W5I-BF-LS, W5I-BF-RS, W5I-BF-LD and W5I-BF-RD Types. This section describes the transmission line design with these antennas.

If you want to use other internal chip antennas, you have to ask the transmission line design to its vendors.

#### 3.1.1. Background information

- Blue: Signal-Ground PAD. Both signal line and ground are to connect here.
- Pink: Antenna signal line (transmission line). Should be 50ohm (recommended Coplanar Waveguide with Ground). Should insert a  $\pi$  or L matching circuit on the line.
- Green/Cyan: Dummy Soldering PAD
- Yellow: Ground
- White: Non-ground area (empty area). If you use a multi-layer PCB, all layers need to be same as the Bottom layer except the Top layer. The location of antenna can be left side or right side of the PCB (Place the antenna as far from copper, metals, and any interfering components as possible.).

Unit: mm

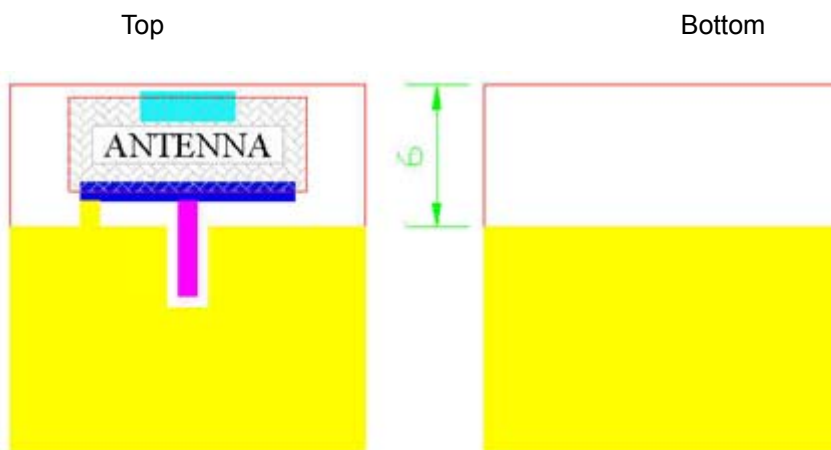

Figure 3-1 a Design Example

### 3.1.2. PCB Design Options

In any cases, the antenna should be located at the edge of the PCB. The following are the options of antenna location based on the ground conditions.

#### 3.1.2.1. W5I-BF-LS Type

- Antenna Location: Top-left side of the PCB
- Ground Conditions: No ground on each side of the antenna

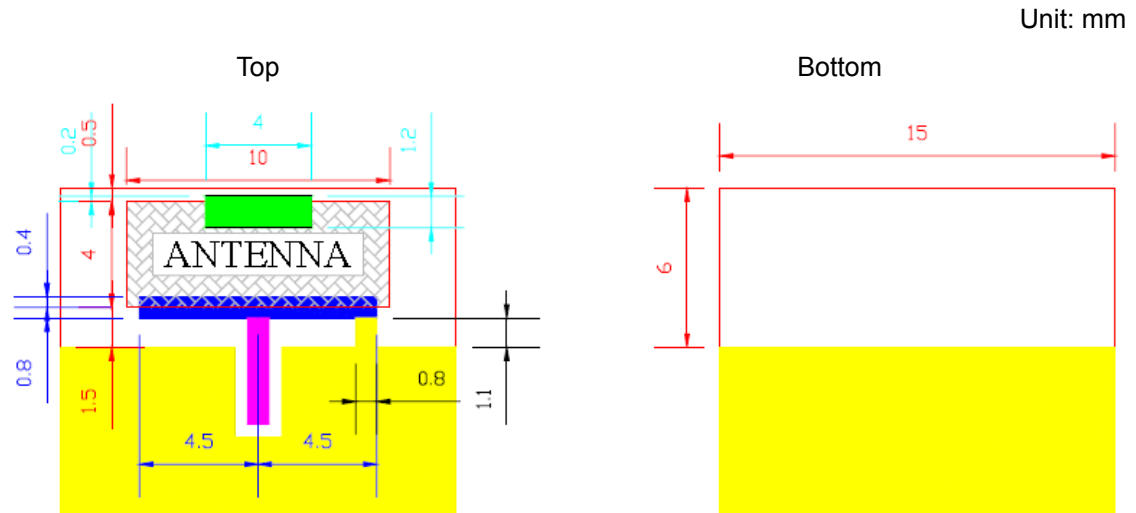

Figure 3-2 W5I-BF-LS Type

#### 3.1.2.2. W5I-BF-RS Type

- Antenna Location: Top-right side of the PCB
- Ground Conditions: No ground on each side of the antenna

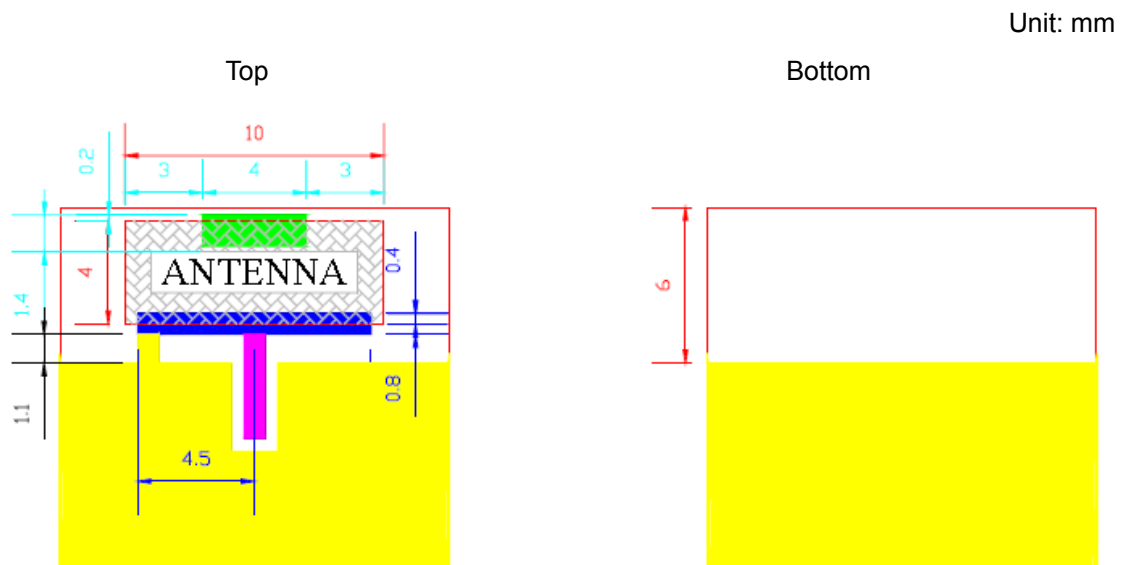
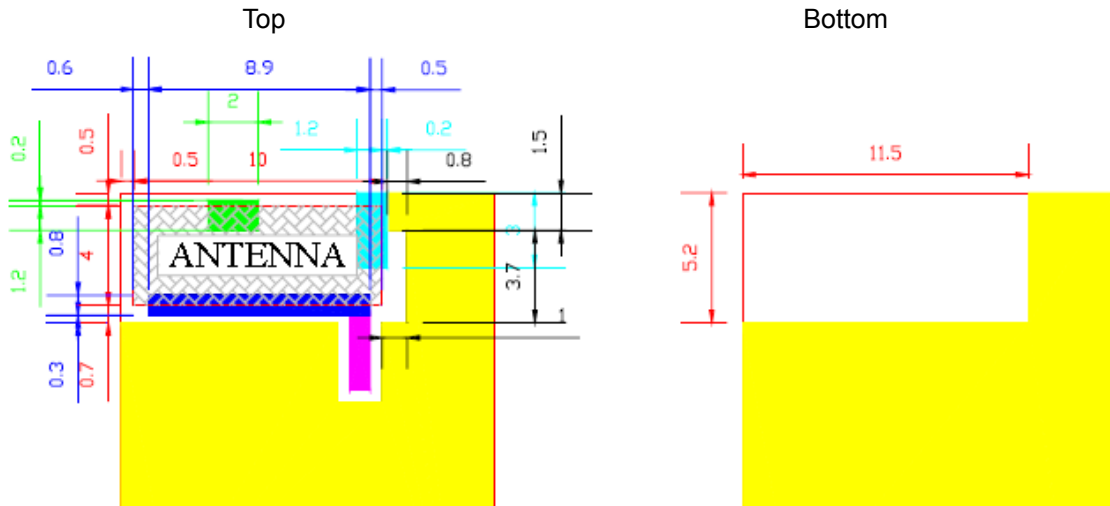

Figure 3-3 W5I-BF-RS Type

**3.1.2.3. W5I-BF-LD Type**

- Antenna Location: Top-left side of the PCB
- Ground Conditions: Right side of the antenna

Unit: mm

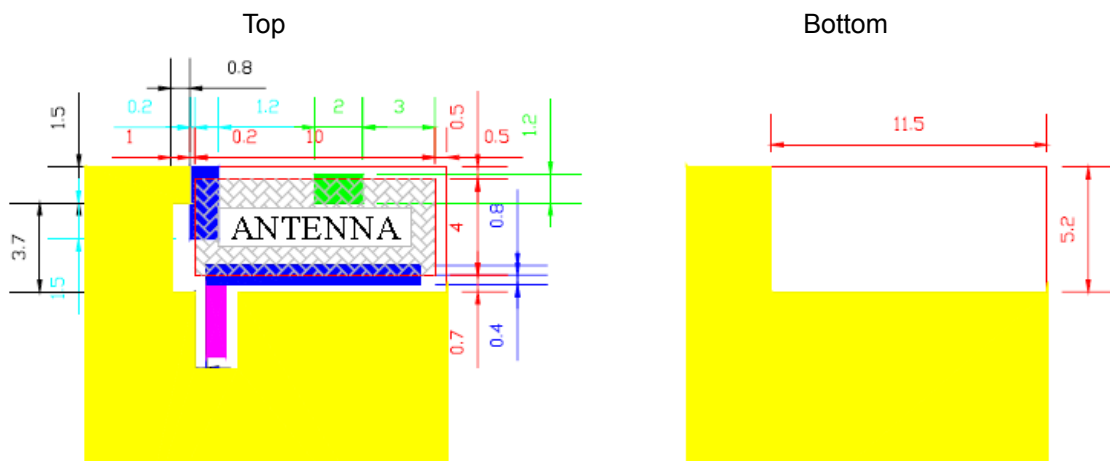

**Figure 3-4 W5I-BF-LD Type**

**3.1.2.4. W5I-BF-RD Type**

- Antenna Location: Top-right side of the PCB
- Ground Conditions: Left side of the antenna

Unit: mm



**Figure 3-5 W5I-BF-RD Type**

### 3.1.3. Design Example and Analysis

This section shows an example design with W51-BF-RD28 and analyzes its design.

- Black: Land PAD for soldering
- Blue: Antenna Signal Line (Transmission Line)
- Cyan: System Ground (digital and RF ground)
- Pink: Silkscreen Printing, Green: Dimension
- PCB: FR4 (Relative Dielectric Constant: about 4.6), PCB Height (Thickness of dielectric): 1mm, Width of Transmission Line: 0.8mm, Width of gap: 0.786

Firstly, it didn't follow the rule of W51-BF-RD Type about the Signal-Ground PAD and the Antenna Signal Line. It should be a right-angled. And the width of gap was too large to have 50ohm impedance. But it can be easily adjusted by putting 2.7nH Inductor at R10 in the L matching circuit. And the ground pad of HCS-03 was attached to the system ground firmly. It also had via holes in system ground area to reinforce its system ground. So that everything was fine.

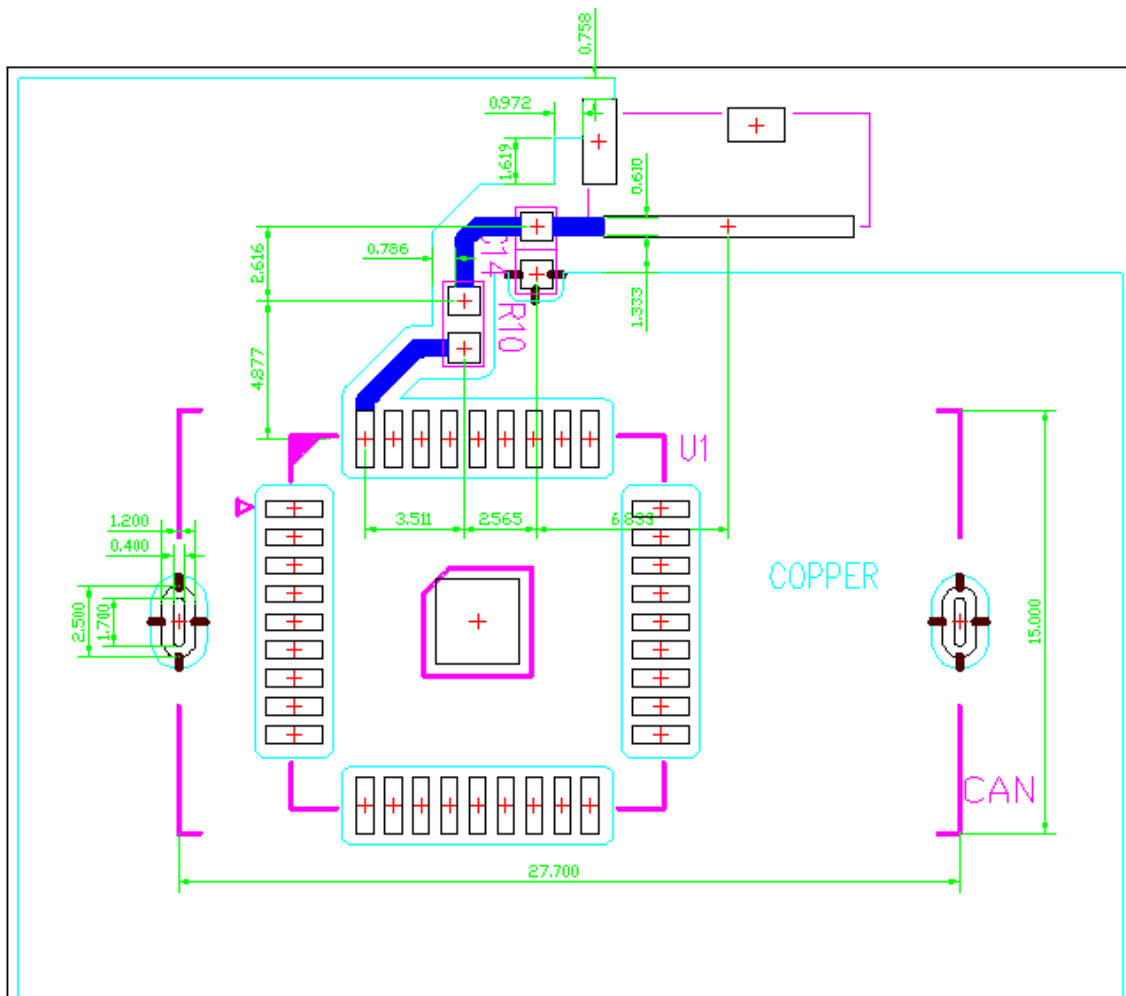

Figure 3-6 Example of Artwork Layout with W51-BF-RD28

### 3.2. SMA Connector Layout

We just put a SMA connector instead of the chip antenna in a design example at 3.1.3. The SMA connector is used for an external antenna.

- Black: Land PAD for soldering
- Blue: Antenna Signal Line (Transmission Line)
- Cyan: System Ground (digital and RF ground)
- Pink: Silkscreen Printing, Green: Dimension
- PCB: FR4 (Relative Dielectric Constant: about 4.6), PCB Height (Thickness of dielectric): 1mm, Width of Transmission Line: 0.8mm, Width of gap: 0.786

The width of gap should be adjusted to 0.2 ~ 0.3mm.

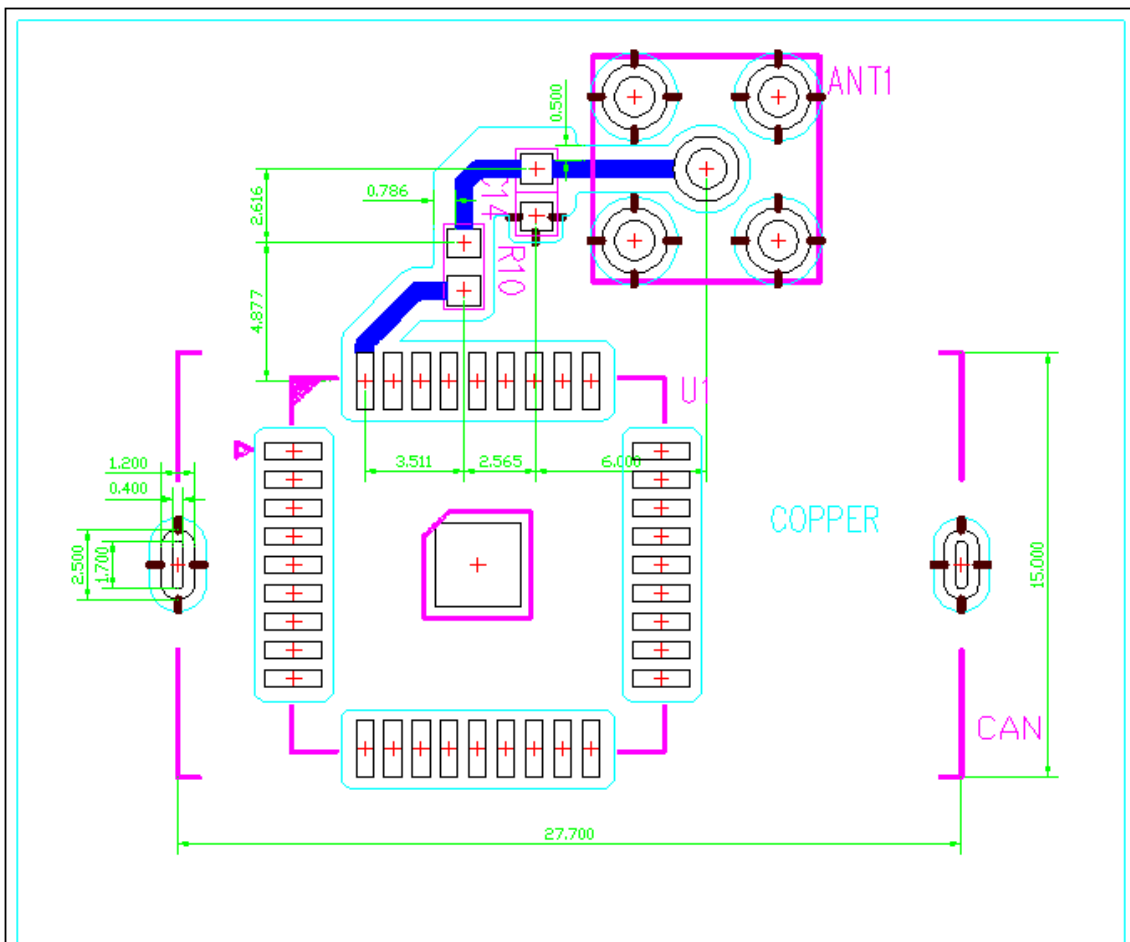
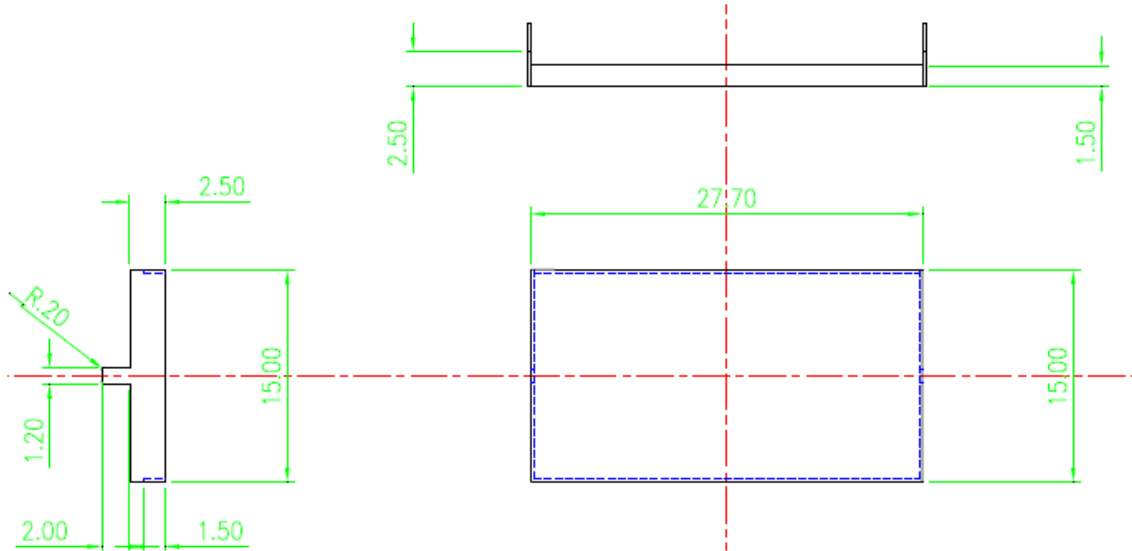

Figure 3-7 SMA Connector Artwork Layout

### 3.2.1. Shield CAN Information

There are two shield can types. The dimension of L type is 15.0 x 27.7 x 2.5 (mm). The dimension of S type is 17.8 x 17.8 x 2.5 (mm).



**Figure 3-8 15.0 x 27.7 x 2.5 (mm) L type Shield CAN**

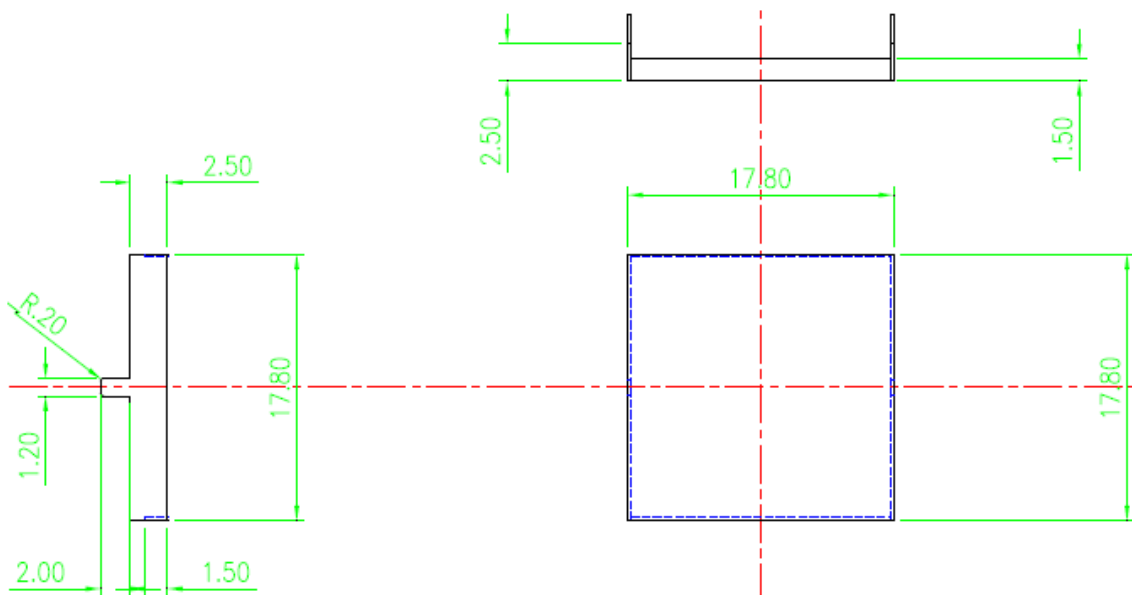

**Figure 3-9 17.8 x 17.8 x 2.5 (mm) S type Shield CAN**

### 3.2.2. Shield CAN Layout Information

You can refer to Figure 3-6 and Figure 3-7 for the layout of L type shield can. The layout of S type shield can is as follows:

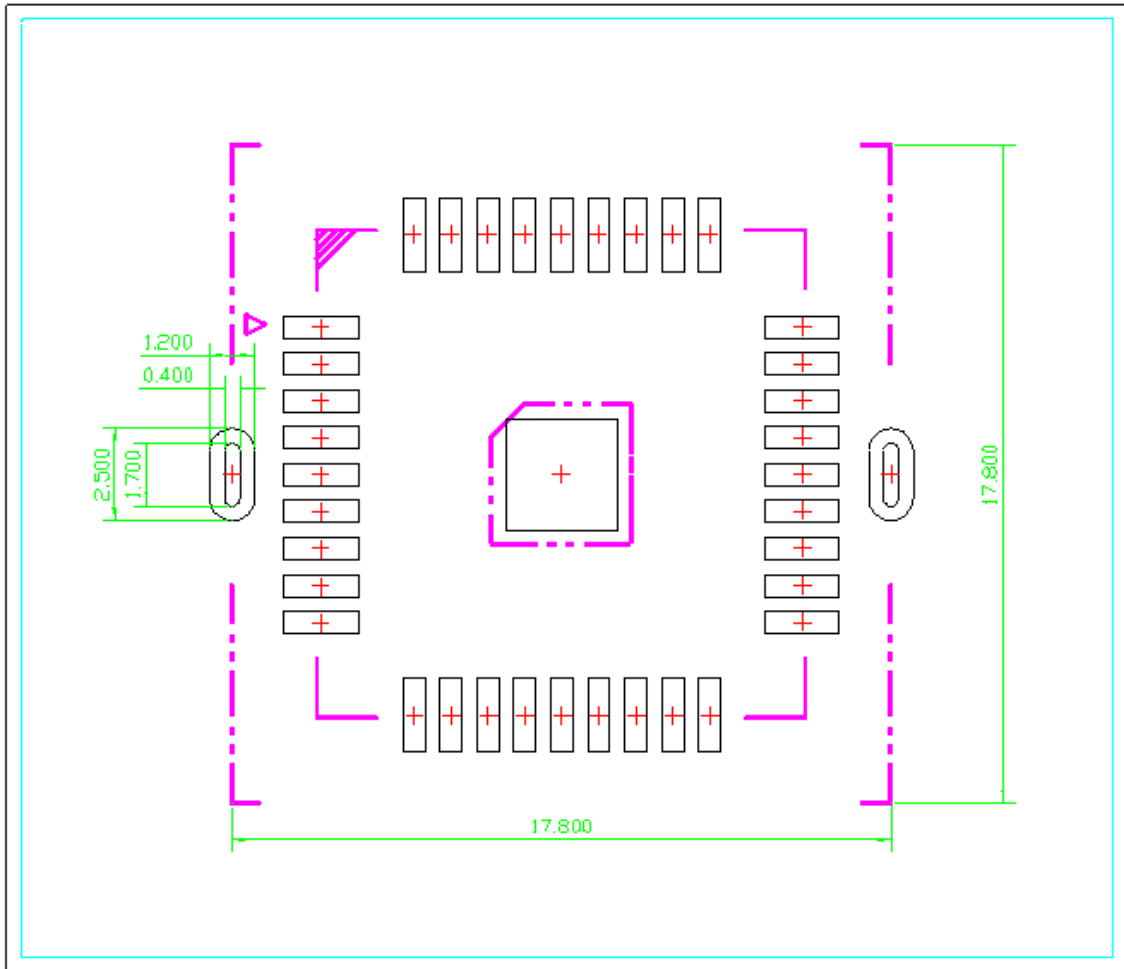

**Figure 3-10 S type Shield CAN Layout**

### 3.3. Common Errors in HCS-03 PCB Design

#### 3.3.1. Ground Land Design for HCS-03 (the center of HCS-03)

The ground land for HCS-03 shall be connected to the system ground thoroughly and firmly. It shall not be separated from the system ground or connected to the system ground via some patterns. It can degrade the RF performance fatally.

#### 3.3.2. Metal Conductors around Antenna

The metal conductors around antenna can degrade the RF performance. Therefore, it shall be removed around antenna.

#### 3.3.3. Transmission Line (Antenna Signal Line) Design

The transmission line shall be designed to have the 50ohm impedance according to the Coplanar Waveguide with Ground. And you shall have a  $\pi$  or L matching circuit on it to have the further adjustments.

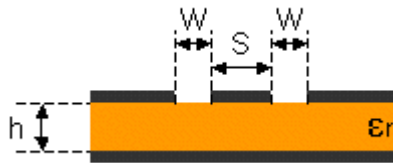

Figure 3-11 Parameters of Coplanar Waveguide with Ground<sup>1</sup>

#### 3.3.4. Bottom Layer Design

The bottom layer shall be designed according to 3.1.1. In case of multi-layer design, all layers need to be same as the Bottom layer except the Top layer.

#### 3.3.5. System Ground Design

Especially two layers PCB, there can be separated the system ground due to the limited space, and the digital signal routing. It should be reinforced the system ground with via holes in the system ground area.

#### 3.3.6. Antenna Layout Design

You shall design the antenna layout according to 3.1. Otherwise you shall not get the designed performance of antenna.

<sup>1</sup> Relative Dielectric Constant ( $\epsilon_r$ ), Width of Transmission Line (S), Width of Gap (W), Thickness of Dielectric (h), Frequency: 2400MHz

## 3.4. SMT Process

### 3.4.1. Metal Mask Recommendation

- Pin Pad Size vs. Metal Mask Opening Size: 1 vs. 1
- Center Ground Opening Size: 2.9mm Square
- Metal Mask Thickness: less than 0.15mm

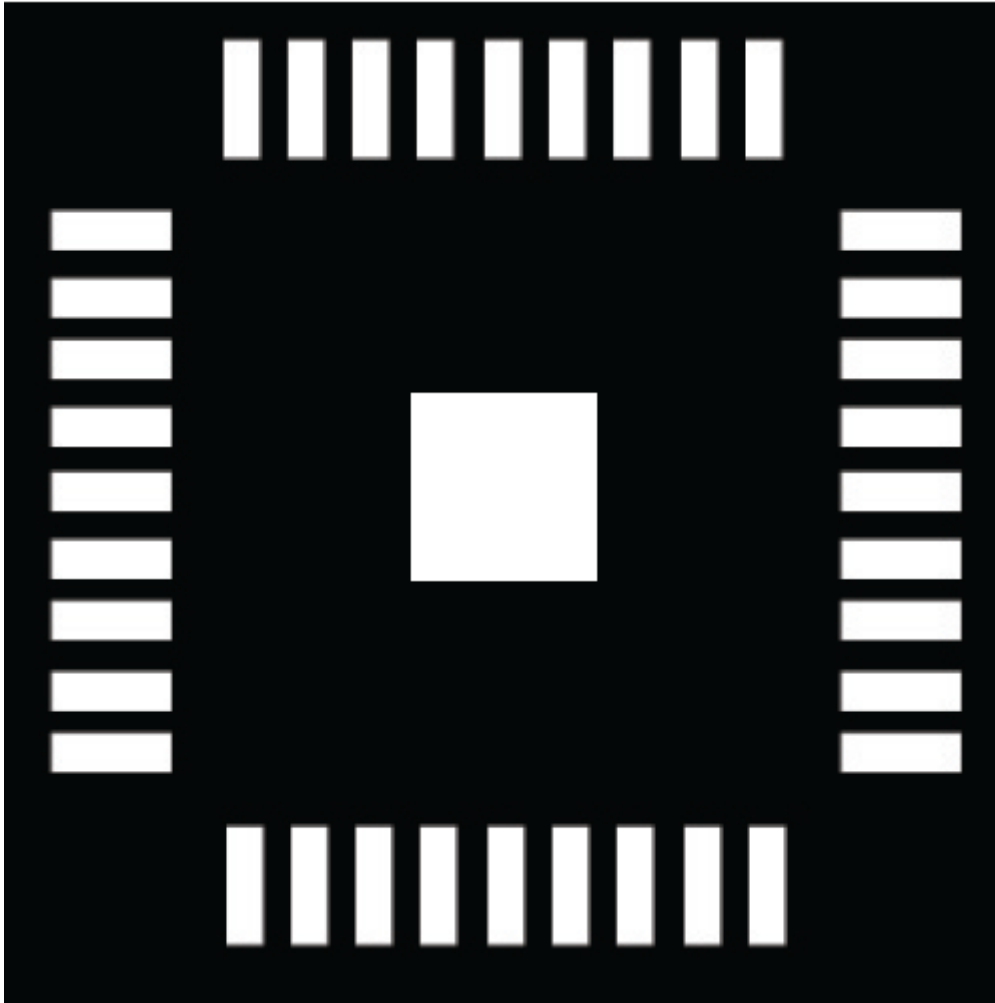
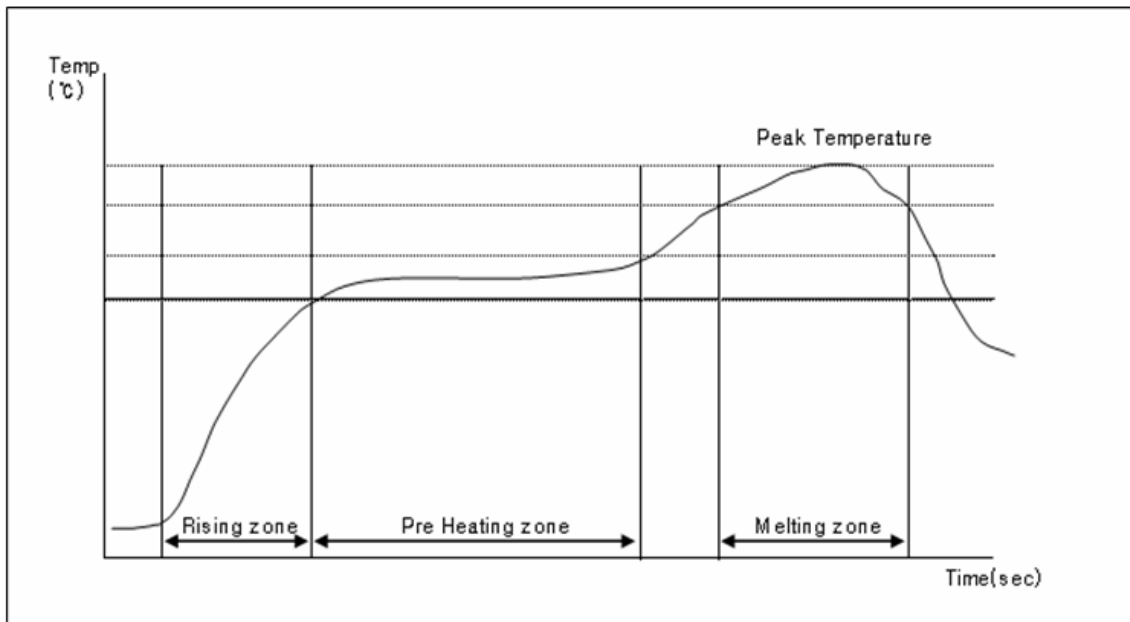

Figure 3-12 HCS-03 Metal Mask

### 3.4.2. Reflow Profile



**Figure 3-13 HCS-03 Reflow Profile**

#### Reflow Parameter

- Pre Heating Zone
  - Temp: 140 ~ 160°C
  - Time: 75 ~ 100sec
- Melting Zone
  - Temp: Above 218°C
  - Time: 30 ~ 50sec
- Peak Temp Max: 260°C

### 3.5. Rework Guidelines

#### 3.5.1. No Hot Gun at Rework

You shall not use a hot gun to rework a HCS-03 on PBA. It will damage the HCS-03 by thermal shock.

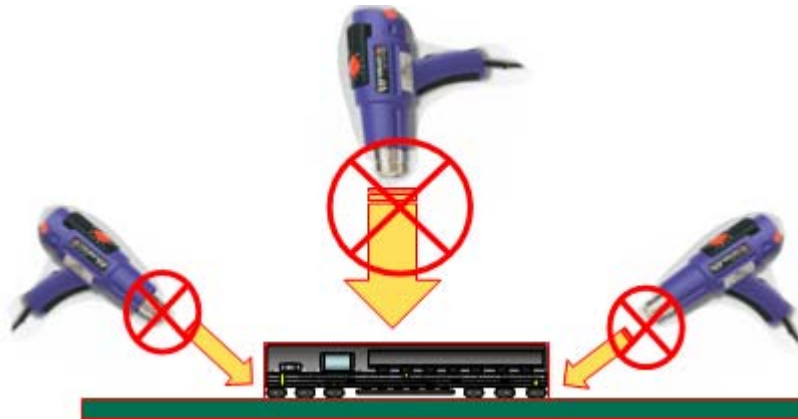

Figure 3-14 No Hot Gun

#### 3.5.2. Rework

You shall use a QFP nozzle to reduce the thermal shock on a HCS-03.

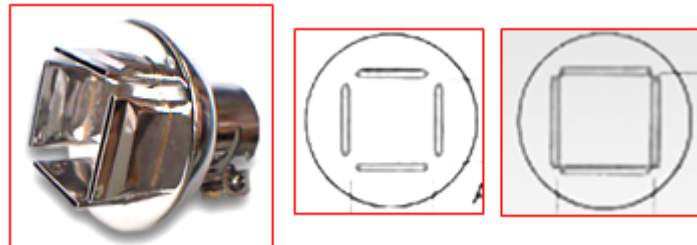

Figure 3-15 QFP Nozzle Examples

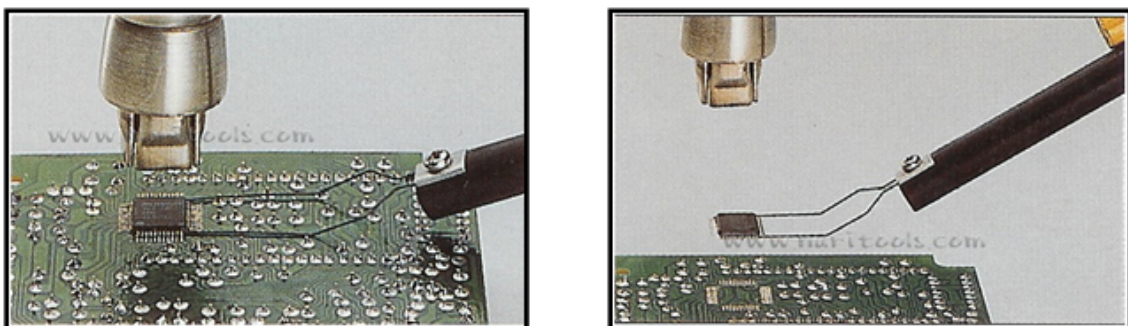

Figure 3-16 Rework Example

### 3.6. Package Information

A tray is used for containing the HCS-03. The size information is as follows:

- Tray Dimension: 13.5 x 31.5 x 7 (mm)
- 160ea/Tray

### 3.7. Ordering Information

**Table 3-1 Ordering Information**

Package			Order Number
Item	Size (mm)	Shipment Method	
HCS-03 Sample with L CAN	N/A	N/A	HCS-03-S-L
HCS-03 Sample with S CAN	N/A	N/A	HCS-03-S-S
HCS-03 with Chip Antenna & L CAN	13.5 x 31.5 x 7	Tray	HCS-03-C-L
HCS-03 with Chip Antenna & S CAN	13.5 x 31.5 x 7	Tray	HCS-03-C-S
HCS-03 with 1dB Antenna & L CAN	13.5 x 31.5 x 7	Tray	HCS-03-E1-L
HCS-03 with 1dB Antenna & S CAN	13.5 x 31.5 x 7	Tray	HCS-03-E1-S
HCS-03 with 2dB Antenna & L CAN	13.5 x 31.5 x 7	Tray	HCS-03-E2-L
HCS-03 with 2dB Antenna & S CAN	13.5 x 31.5 x 7	Tray	HCS-03-E2-S
HCS-03 with 4dB Antenna & L CAN	13.5 x 31.5 x 7	Tray	HCS-03-E4-L
HCS-03 with 4dB Antenna & S CAN	13.5 x 31.5 x 7	Tray	HCS-03-E4-S

MOQ:

- HCS-03-S: 10ea
- Others: 100ea

### 3.8. Contact Information

HandyWave Co., Ltd.

202-4 Yatap-dong, Bundang-gu, Seongnam-shi, Gyunggi Province, 463-070, Korea

Tel: 82-31-709-8900

Fax: 82-31-708-9455

E-mail:

- Sales: [blueahn@handywave.com](mailto:blueahn@handywave.com)

- Technical Support: [support@handywave.com](mailto:support@handywave.com)

Home Page: <http://handywave.com/index3.htm>

Attachment 1. Reference Schematic

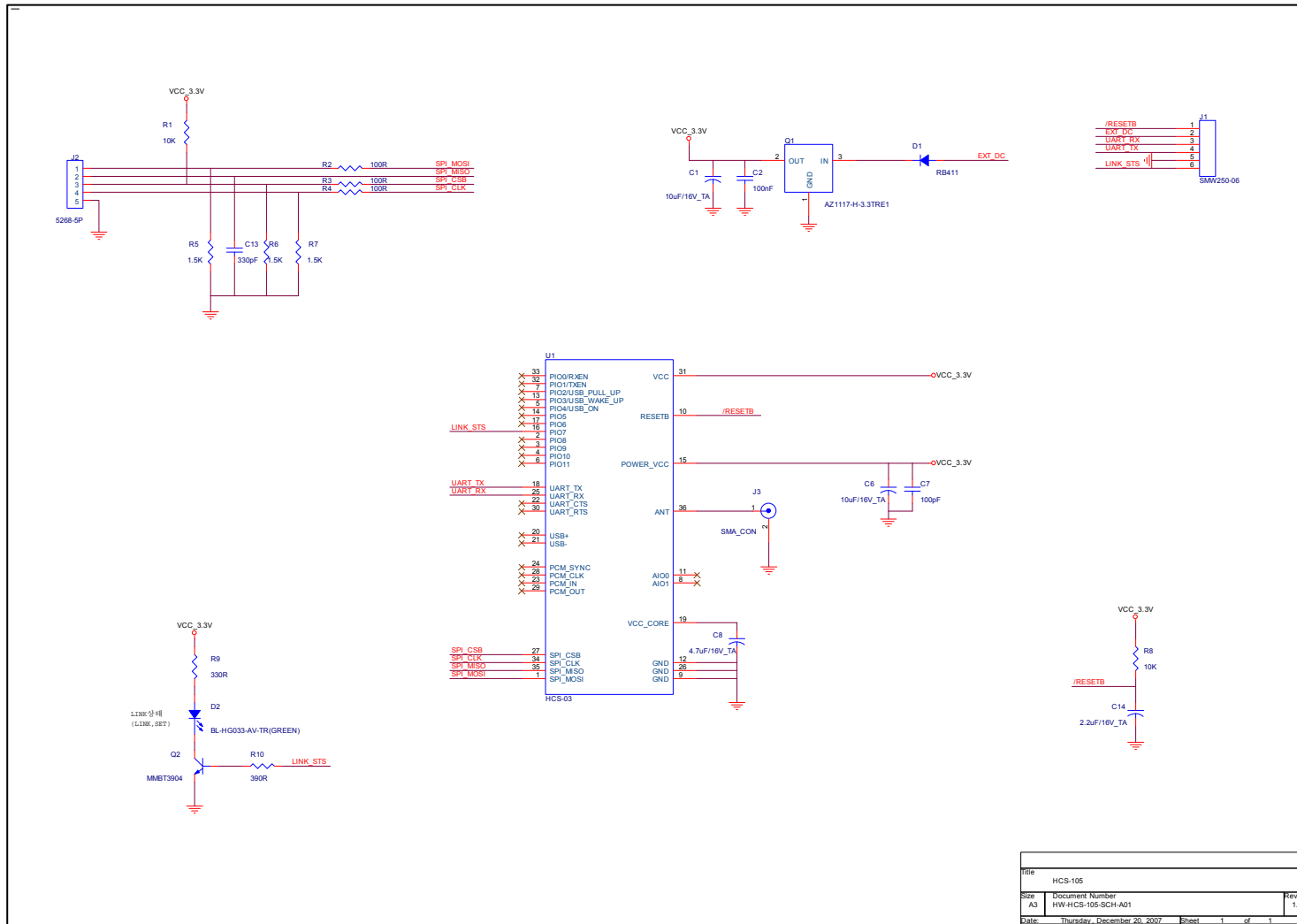

Title		
HCS-105		
Size	Document Number	Rev
A3	HW-HCS-105-SCH-A01	1.0
Date	Thursday, December 20, 2007	Sheet 1 of 1

**Attachment 2. Bill of Materials**

No	Reference	Parts	Quantity	Description
1	U1	HCS-03	1	Bluetooth Module
2	Q1	AZ1117-H-3.3TRE1	1	LDO Regulator
3	Q2	MMBT3904	1	Transistor
4	D1	RB411D	1	DIODE
5	D2	BL-HG033-AV-TRB	1	LED
6	R1, R8	10K SMD 1608	2	Resistor
7	R2,R3,R4	100R SMD 1608	3	Resistor
8	R5,R6,R7	1.5K SMD 1608	3	Resistor
9	R9	330R SMD 1608	1	Resistor
10	R10	390R SMD 1608	1	Resistor
11	C1,C6	10uF/16V-TA	2	Tantalum Capacitor (A SIZE)
12	C2	100nF SMD 1608	1	Ceramic Capacitor
13	C13	330pF SMD 1608	1	Ceramic Capacitor
14	C7	100pF SMD 1608	1	Ceramic Capacitor
15	C8	4.7uF/16V TA	1	Tantalum Capacitor (A SIZE)
16	C14	2.2uF/16V TA	1	Tantalum Capacitor (A SIZE)
17	J1	SMAW250-06	1	UART and Control Signal Connector
18	J2	5268-5P	1	SPI Connector
19	J3	SMA-CON	1	Antenna Connector
20		PCB	1	PCB
21		Shield can	1	